

Verdin Industrial Heatsink

Datasheet

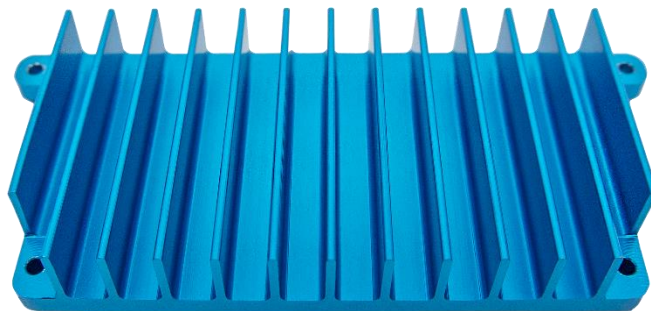

Revision History

Date	Doc. Rev.	Heatsink Version	Changes
16-Apr-2021	Rev. 0.9	V1.0A	Initial release
			Product picture updated Preliminary markings removed
7-Nov-2021	Rev. 1.0	V1.0B	Section 2.1: added missing thermal resistance valued to the table Section 4: updated product pictures, added general tolerances Section 5.1: added details about screws maximum tightening torque Small improvements throughout the whole document

Contents

1. Introduction	4
1.1. <i>Reference Documents</i>	4
1.1.1 Verdin Family Specification	4
1.1.2 Verdin Carrier Board Design Guide	4
1.1.3 Toradex Developer Website - Verdin Computer Modules	4
1.1.4 Toradex Developer Website - Verdin Carrier Boards	4
1.1.5 Thermal Interface Material (TGP 3000) Datasheets.....	4
2. Technical Specifications	5
2.1. <i>Verdin Industrial Heatsink Type 1</i>	5
3. Compatibility	6
4. Mechanical Dimensions	7
4.1. <i>Heatsink Dimensions</i>	7
4.2. <i>Overall Dimensions</i>	8
4.3. <i>General Tolerances</i>	8
5. Assembly	9
5.1. <i>Assembly procedure</i>	9
6. Product Compliance	10
7. Storage Requirements	11

1. Introduction

The Verdin Industrial Heatsink is a complete thermal solution. It is mounted to the Verdin carrier board by means of four M2x10mm Phillips cross slot screws.

1.1. Reference Documents

For detailed technical information about suitable computer modules, please refer to the documents listed below.

1.1.1 Verdin Family Specification

<https://docs.toradex.com/109262-verdin-family-specification.pdf>

1.1.2 Verdin Carrier Board Design Guide

<https://docs.toradex.com/108140-verdin-carrier-board-design-guide.pdf>

1.1.3 Toradex Developer Website - Verdin Computer Modules

<https://developer.toradex.com/products/verdin-imx8m-mini>

<https://developer.toradex.com/products/verdin-som-family/modules/verdin-imx8m-plus>

1.1.4 Toradex Developer Website - Verdin Carrier Boards

<https://developer.toradex.com/products/verdin-development-board>

<https://developer.toradex.com/products/dahlia-carrier-board>

1.1.5 Thermal Interface Material (TGP 3000) Datasheets

The datasheets of Thermal Interface Material used on the Verdin Industrial Heatsink can be downloaded by using the following link:

<http://tds.henkel.com/tds5/Studio/ShowPDF/243%20NEW-EN?pid=TGP%203000&format=MTR&subformat=HYS&language=EN&plant=WERCS>

2. Technical Specifications

2.1. Verdin Industrial Heatsink Type 1

Material	Aluminum alloy AL6063-T5	Remarks
Surface	Degreased, blue anodized	
Thermal conductivity	190 to 221 W/(mK)	Temperature Range: 40°C to 100°C
Weight	Approx 33 grams	
TIM, Thermal conductivity	3.0 W/(mK)	Thermal Interface Material (TGP 3000)
TIM, Flame Rating	UL 94V-0	
TIM, Volume Resistivity	1x10 ⁹ Ohm-meter	
TIM, Dielectric Constant	7.0 @ 1000 Hz	
TIM, Dielectric Breakdown Voltage	>3000 V(AC)	
TIM, Continuous Use Temperature	-60°C to +200°C	
TIM, Density	3.2 g/cc	
TIM, Young's Modulus	26 PSI	
TIM, Hardness Bulk Rubber	30 (Shore 00)	
Thermal resistance (Module-Alu)	< 1.55°C/W (Estimated)	
Thermal resistance (Alu-Ambient)	< 9.1°C/W (Estimated)	

3. Compatibility

The following table shows the compatibility of the Verdin Industrial Heatsinks and the Verdin modules:

Verdin Module	Compatible Verdin Industrial Heatsink
Verdin iMX8M Mini V1.1A and newer	23111000 Verdin Industrial Heatsink Type 1 V1.0A and newer
Verdin iMX8M Plus V1.0B and newer	

4. Mechanical Dimensions

The following drawings illustrate the mechanical dimensions of the Verdin Industrial Heatsink. All measurements are in millimeters (mm); the images are not to scale.

4.1. Heatsink Dimensions

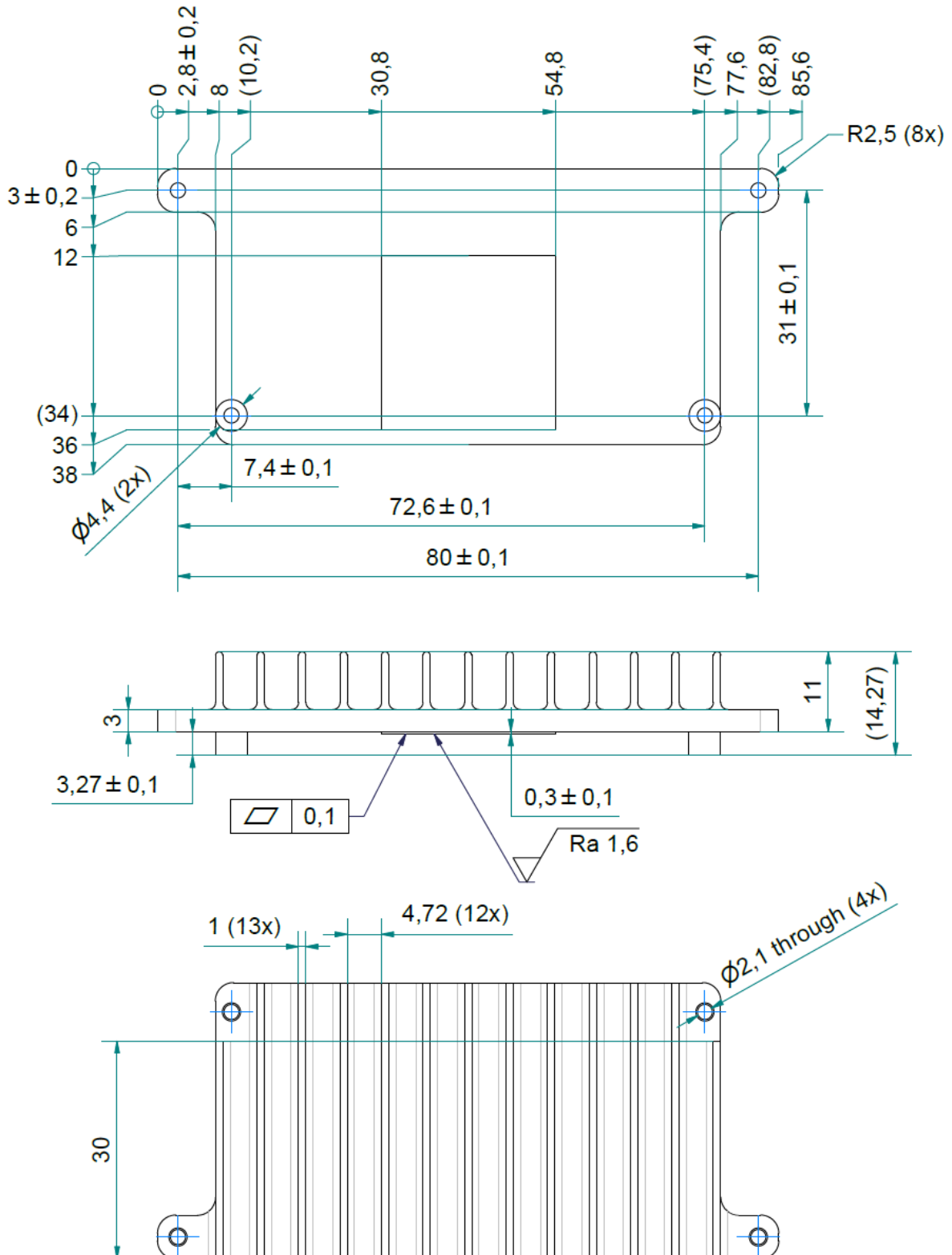

Figure 1-A: Verdin Industrial Heatsink Type 1 Heatsink Dimensions

4.2. Overall Dimensions

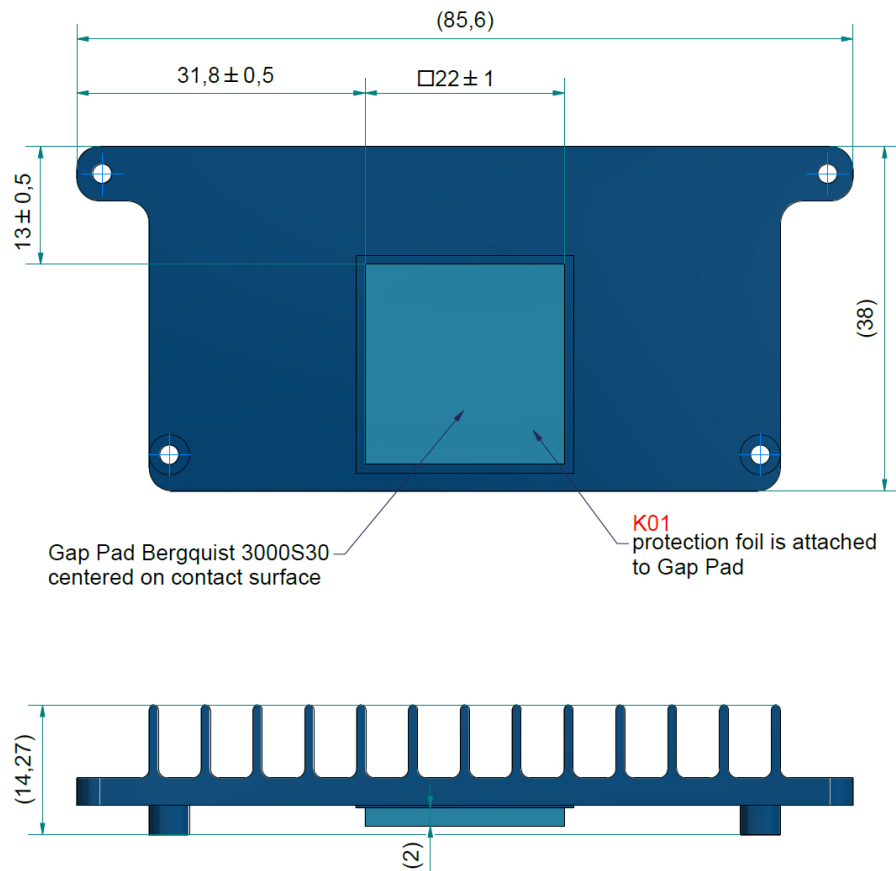

Figure 1-B: Verdin Industrial Heatsink Type 1 Overall Dimensions

4.3. General Tolerances

When not explicitly specified, the following tolerances apply to the product:

- Machining dimensions: DIN ISO 2768mK
- Extrusion dimensions: DIN EN12020-2
- Diecasting dimensions: DIN1688-4 GTA14

5. Assembly

Assembly must be done very carefully since putting the Verdin Industrial Heatsink in a wrong orientation will damage the Verdin module or prevent the system from working correctly.

5.1. Assembly procedure

The following procedure indicates how to attach the Verdin Industrial Heatsink to the Verdin module to complete the heatsink solution. Please read the instructions and follow the procedure very carefully to ensure that the module does not get damaged. Necessary precautions should be taken to avoid the build-up of electrostatic charges.

1. Clean the processor's top surface using an anti-static cloth.
2. Insert the Verdin module in the SO-DIMM socket X1 on the Verdin carrier board.
3. Carefully remove the plastic foil from the TIM.
4. Carefully align the mounting holes of the Verdin Industrial Heatsink to be in line with the stand-offs available on the Verdin carrier board. Place the Verdin Industrial Heatsink on the system.
5. Use four units of M2-sized screws to affix the Verdin Industrial Heatsink to the system. The maximum tightening torque specified by the spacers mounted on the Verdin carrier boards is 0.2 Nm.
4. Done. The system is now ready for use.

6. Product Compliance

Up-to-date information about product compliance such as RoHS, CE, UL-94, Conflict Mineral, REACH, etc. can be found on our website at <http://www.toradex.com/support/product-compliance>

7. Storage Requirements

Shelf life is the period of time that a product is expected to remain within its approved product specification while stored under defined conditions.

The most significant factor limiting the Verdin Industrial Heatsink's shelf life is the mylar film used to protect the TIM when the product is not assembled on the computer module.

The following table shows the storage requirements and the shelf life of the Verdin Industrial Heatsink.

Short periods during which the product is subjected to slightly off-specification environmental conditions will not significantly impact shelf life.

Storage Measures	Ambient Atmosphere	Storage Temperature	Storage Relative Humidity	Maximum Storage Time
Original packing	Air	22°C to 28°C	40% to 60%	12 months

DISCLAIMER:

Copyright © Toradex AG. All rights are reserved. The information and content in this document are provided “as-is” with no warranties of any kind and are for informational purposes only. Data and information have been carefully checked and are believed to be accurate; however, no liability or responsibility for any errors, omissions or inaccuracies is assumed.

Brand and product names are trademarks or registered trademarks of their respective owners. Specifications are subject to change without notice.